

## Platinum Resistance Temperature Detector

M 219

M-series PRTDs are designed for large volume applications where long term stability, interchangeability and accuracy over a large temperature range are vital. Typical applications are Automotive, Appliances, HVAC, Energy Management, Life Science and the process industry.

| Nominal Resistance R0 | Tolerance<br>DIN EN 60751<br>1996-07 | Tolerance<br>DIN EN 60751<br>2009-05 | Order Number<br>Plastic Box | Lead Length (L)<br>± 1mm |
|-----------------------|--------------------------------------|--------------------------------------|-----------------------------|--------------------------|
| 1000 Ohm at 0°C       | Class B                              | F 0.3                                | 32 208 739                  | 7                        |
|                       | Class 2B                             | F 0.6                                | 32 208 728                  | 7                        |

The measuring point for the nominal resistance is defined at 6mm from the end of the sensor body.

|                                 |   |  |
|---------------------------------|---|--|
| <b>Specification</b>            | DIN EN 60751  |  |
| <b>Temperature range</b>        | -70°C to +500°C (continuous operation)<br>(temporary use to 550°C possible)<br>Tolerance Class B und 2B: -70°C +500°C |  |
| <b>Tolerance class:</b>         | Class B and 2B  |  |
| <b>Temperature coefficient</b>  | TC = 3750 ppm/K   |  |
| <b>Leads</b>                    | Pt clad Ni- wire<br>Recommend connection technology:<br>Welding, Crimping and Brazing                                 |  |
| <b>Long-term stability</b>      | Max. R <sub>0</sub> -Drift 0.04% after 1000h at 500°C   |  |
| <b>Vibration resistance</b>     | at least 40g acceleration at 10 to 2000 Hz,<br>depending on installation  |  |
| <b>Shock resistance</b>         | at least 100g acceleration with 8ms<br>half-sine-wave, depends on installation  |  |
| <b>Environmental conditions</b> | unhoused for dry environments only  |  |
| <b>Insulation resistance</b>    | > 100 MΩ at 20°C<br>> 2 MΩ at 500°C   |  |
| <b>Self heating</b>             | 0.5 K/mW at 0°C   |  |
| <b>Response time</b>            | Water current (v= 0.4m/s):  | t <sub>0,5</sub> = 0.05s<br>t <sub>0,9</sub> = 0.15s |
|                                 | Air stream (v= 2.0m/s):   | t <sub>0,5</sub> = 3.0s<br>t <sub>0,9</sub> = 10.0s  |
| <b>Measuring current</b>        | 1000Ω: 0.1 to 0.3mA<br>(Self heating has to be considered)  |  |

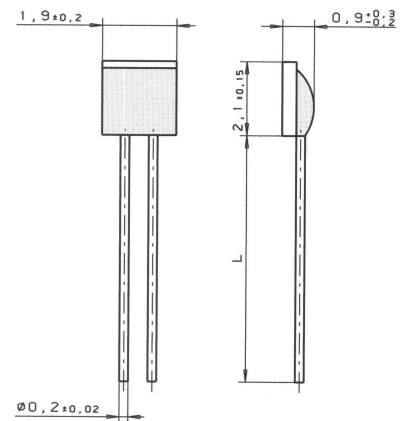

We reserve the right to make alterations and technical data printed. All technical data serves as a guideline and does not guarantee particular properties to any products.

### Heraeus Sensor Technology USA

1901 Route 130  
North Brunswick, NJ 08902  
Phone 732-940-4400 Fax 732-940-4445  
Email info.hst-us@heraeus.com  
www.hst-us.com

Name of document: 30910063 Index B  
Status: 08/2010