

Platinum Resistance Temperature Detector

C 220

The C series thin-film PRTDs combine the ideal curve characteristics of ceramic wire-wound RTDs with the vibration resistance of glass wire-wound RTDs and represent an excellent alternative to wire-wound RTDs. They are characterized by high long-term stability, excellent temperature shock resistance and a wide temperature range of -196°C to +150°C. The deviation from the DIN EN 60751 (according to IEC 751) characteristic curve is minimal over the entire temperature range, they show no hysteresis. These features make them best suited for applications in aerospace, chemical and power generation plants and analytical equipment.

Nominal Resistance R0	Tolerance DIN EN 60751 1996-07	Tolerance DIN EN 60751 2009-05	Order Number Plastic Box
100 Ohm at 0°C	Class B	F 0.3	32 207 399

The measuring point for the nominal resistance is defined at 8mm from the end of the sensor body.

Specification	DIN EN 60751	
Nominal resistance	100Ω at 0°C	
Temperature range	-196°C to +150°C Tolerance Class B: -196°C to +150°C	
Temperature coefficient	TCR = 3850 ppm/K	
Leads	AgPd- wire	
Lead lengths (L)	10mm ±1mm	
Long-term stability	max. R0-Drift 0.03% after 1000 h at 150°C	
Environmental conditions	unhoused for dry environments only	
Vibration resistance	at least 40g acceleration at 10 to 2000 Hz, depends on installation	
Shock resistance	at least 100g acceleration with 8ms half sine wave, depends on installation	
Insulation resistance	> 100 MΩ at 150°C	
Self heating	0.4 K/mW at 0°C	
Response time	water current (v= 0.4m/s):	t _{0.5} = 0.06s t _{0.9} = 0.20s
	air stream (v= 2m/s):	t _{0.5} = 3.5s t _{0.9} = 13.0s
Measuring current	100Ω: 0.3 to 1.0mA (self heating has to be considered)	
Note	Other tolerances, values of resistance and wire lengths are available on request.	

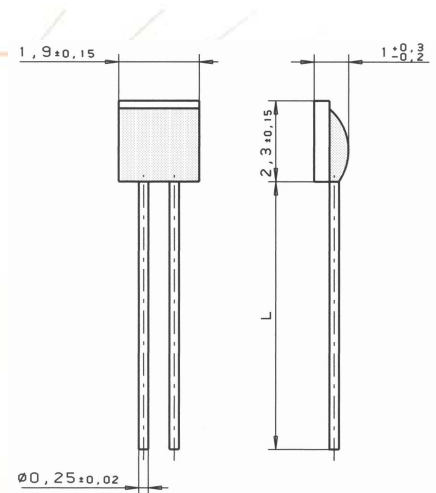

We reserve the right to make alterations and technical data printed. All technical data serves as a guideline and does not guarantee particular properties to any products.

Heraeus Sensor Technology USA

1901 Route 130
 North Brunswick, NJ 08902
 Phone 732-940-4400 Fax 732-940-4445
 Email info.hst-us@heraeus.com
www.hst-us.com

Name of document: 30910000 Index A
 Status: 10/2009