

Platinum Resistance Temperature Detector

MN 222

MN- series PRTDs are designed for large volume applications where long term stability, interchangeability and accuracy over a large temperature range are vital. Typical applications are Automotive, White Goods, HVAC, Energy management, Medical and Industrial equipment.

Nominal Resistance R0	Tolerance DIN EN 60751 1996-07	Tolerance DIN EN 60751 2009-05	Order Number Plastic Bag
100 Ohm at 0°C	Class A	F 0.15	32 207 759
	Class B	F 0.3	32 207 758
	Class 2B	F 0.6	32 207 757
500 Ohm at 0°C	Class B	F 0.3	32 207 756
	Class 2B	F 0.6	32 207 755
1000 Ohm at 0°C	Class A	F 0.15	32 207 754
	Class B	F 0.3	32 207 753
	Class 2B	F 0.6	32 207 751

The measuring point for the nominal resistance is defined at 8mm from the end of the sensor body.

Specification	DIN EN 60751 (according to IEC 751)
Temperature range	Class B and 2B: -70°C to +500°C (continuous operation) (temporary use to 550°C possible) Class A: -50°C to +300°C (exposure to temperatures above +300°C will result in permanent tolerance shift from Class A to Class B)
Tolerance range	Tolerance Class B: -70°C to +500°C Tolerance Class A: -50°C to +300°C Tolerance Class 2B: -70°C to +500°C
Temperature coefficient	TCR = 3850 ppm/K
Leads	Ni- wire Recommend connection technology: Welding and Brazing
Lead lengths (L)	10mm ±1mm
Ambient conditions	Unhoused for dry environments only
Insulation resistance	> 100 MΩ at 20°C; > 2 MΩ at 500°C
Self heating	0.4 K/mW at 0°C
Response time	water current (v= 0.4m/s): $t_{0.5} = 0.05s$ $t_{0.9} = 0.15s$ air stream (v= 2m/s): $t_{0.5} = 3.0s$ $t_{0.9} = 10.0s$
Measuring current	100Ω: 0.3 to 1.0mA 500Ω: 0.1 to 0.7mA 1000Ω: 0.1 bis 0.3mA (self heating has to be considered)
Application advice	1. To avoid shear forces on the connection area, the connection wires may be neither split or bent. The bending may only take place 3 mm after the element, using a bending or splitting tool. 2. Other nominal values, lengths and temperature coefficients on request. 3. Due to a production-caused oxide layer coating the leads, soft-soldering is restricted.
Note	Other tolerances, values of resistance are available on request.

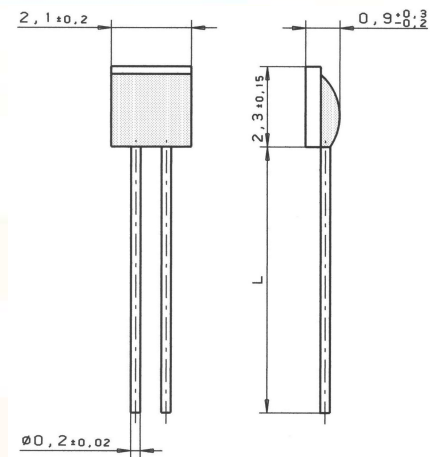

We reserve the right to make alterations and technical data printed. All technical data serves as a guideline and does not guarantee particular properties to any products.

Heraeus Sensor Technology USA

1901 Route 130
North Brunswick, NJ 08902
Phone 732-940-4400 Fax 732-940-4445
Email info.hst-us@heraeus.com
www.hst-us.com

Name of document: 30910060 Index B
Status: 11/2011